

# POLISHER

## NF-15P



# GRAIN POLISHER NF-15P

The horizontal Polisher mod. NF-15P is the ideal solution for removing bran from cereals, like wheat, rice, spelt, oat, etc., with a minimum breaking of the kernel.

This process allows to pull the bacterial count down and reduces the ash content in the flours obtained by polished cereals.

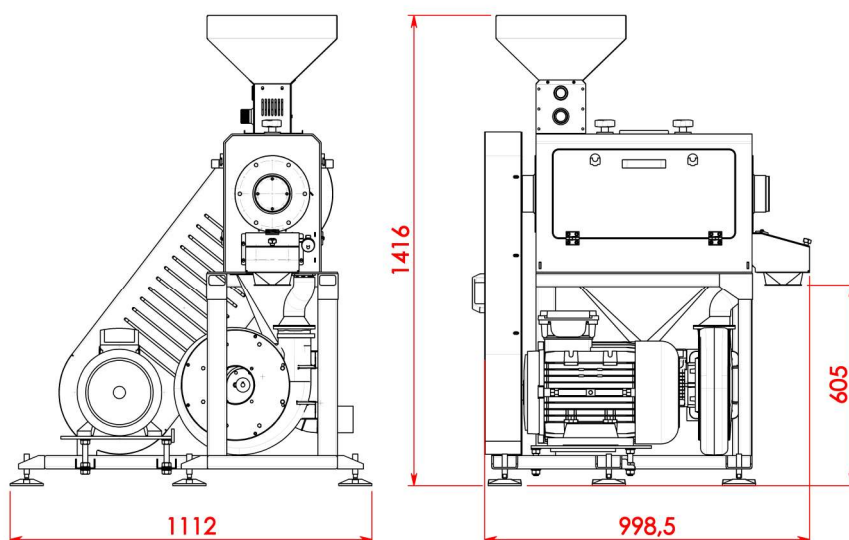

The machine is equipped with a charge hopper that regulates the product's flow. The outlet is equipped with an adjustable device which allows to regulate the staying time of the kernels inside the machine and, consequently, their husking degree.

Inside the frame in welded cast iron and stove painted, there is a fan blowing air inside the rotor, realized in abrasive material, that allows an easier dust extraction from the husking chamber.

This machine is generally connected to a Pneumatic System having the purpose of removing the refuse dust and of keeping the Polisher in depression, avoiding so dust emission in the environment.

MODEL	TENSION	ABSORPTION	POWER	REVOLUTIONS	CAPACITY
NF-15	V.400/690 HZ. 50	18,4 A	7,5 Kw	1400	400 Kg/h
NF-15	V.400/690 HZ. 50	21,5 A	11 Kw	1400	800 Kg/h
NF-15	V.400/690 HZ. 50	27,5 A	15 Kw	1400	1400 Kg/h

**FORLI'** 47122 - ITALY  
VIA UGO BULI, 2 (z.i.)  
Tel. +39 0543 796165  
Fax +39 0543 723237



<http://www.partisani.com> — E-mail: [info@partisani.com](mailto:info@partisani.com)

ITALY - 20124 **MILANO**  
PIAZZA DUCA D'AOSTA, 8  
Tel. +39 02 6692734  
Fax +39 02 6692634